

CLASSIC CAR CONNECTION AG

SMARTSCREEN FITTING & OPERATING – ALL VERSIONS SS01, SS02, SS04, SS05/N, SS05/P

The SMARTSCREEN may be fitted on any convenient surface either under the bonnet or behind the dashboard of the vehicle. Fixing is either by self tapping screws or by self adhesive pads. Fitting is straightforward providing the following instructions are followed and reference to the drawings over are made. SS05 models have optional wipe on wash functions, either for positive or negative switching washer pumps.

In the interest of safety we advise that you disconnect the vehicle's battery.

The SMARTSCREEN has either 4, 5 or 6 terminals depending on model.

Connect (-), (Sw), (+), (W) as follows

- 1 (-) & (+) should be connected to earth and a convenient feed in the fuse box that is on when the ignition is on. Please note that on -ve earth cars (-) connects to earth but on positive earth cars (+) connects to earth.
- 2 Identify the wire from the wiper switch to the wiper motor that receives a continuous supply only when the wiper switch is in the standard speed position, normally black with green trace (BG). This wire should be detached from the wiper switch and connected to (W). Connect a new wire from (Sw) to where you detached the wire from the wiper switch. Alternatively if the wire between the wiper switch and motor is long enough cut this and attach the appropriate ends to (W) & (Sw).

Connect (P)

- 1 Identify the wire from the wiper switch to the wiper motor park switch, normally brown with light green trace (NLG). Using the splice connector supplied make a connection to (P).

Connect (Wsh)

- 1 Identify the wire from the washer switch to the washer motor, normally light green with black trace (LGB). Using the splice connector supplied make a connection to (Wsh)

Double check your work and when satisfied all is correct, reconnect the battery.

The SMARTSCREEN will enable intermittent operation of the vehicle's wiper with intervals of between three and thirty seconds. The standard speed wiper switch is used to set the delay intervals and these can be changed as often as desired. If you have the WASH-WIPE version, when the existing washer is used the wipers will wipe three or four times automatically. This will not affect the intermittent function of SMARTSCREEN with WASH-WIPE if already in use. An LED is provided to assist you with understanding the operation of the unit.

To operate the SMARTSCREEN

- 1 Start vehicle and flick standard speed wiper switch briefly on, the wiper will wipe once. LED will flicker.
- 2 After the desired delay, which must be longer than three seconds but less than thirty, flick the switch briefly again – the wiper will wipe once and continue to wipe at the set delay. LED will light continuously. NB the unit will ignore any inputs whilst the wiper is moving.
- 3 To set a new delay flick the switch briefly again – the wiper will wipe once. LED will flicker. After the new delay flick the switch again and the wiper will wipe and continue to wipe at the new delay. LED will light continuously.
- 4 To cancel the wiper, flick the switch briefly, the wiper will wipe once, do not flick the switch again within thirty seconds. (The unit will give up looking for a second switch after thirty seconds). Alternatively switch the wipers on continuously for five seconds or more and then off again. Once the unit is reset the LED will be off.
- 5 To wash the screen press the washer switch in the usual way, the wiper will now start wiping and will continue to wipe for three or four wipes after the washer switch is released. If you have already selected intermittent wipe this will resume after three or four continuous wipes.

If you have difficulty in installing or operating your SMARTSCREEN please email: help@smart-screen.co.uk

CLASSIC CAR CONNECTION AG

Normal wiring for wipers & washers

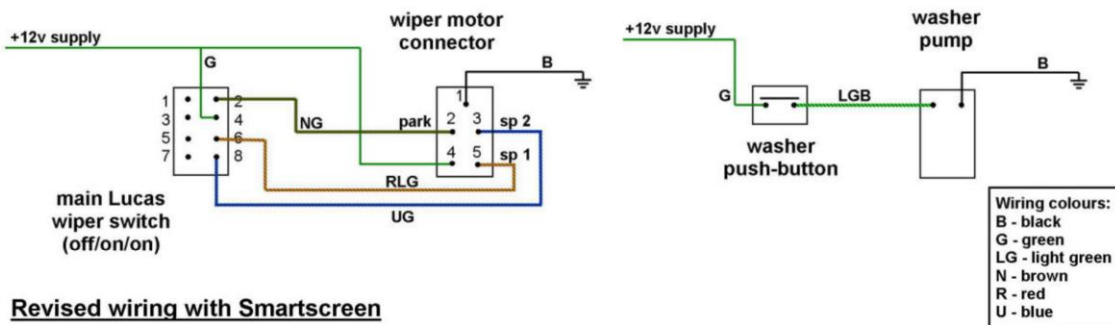

Revised wiring with Smartscreen

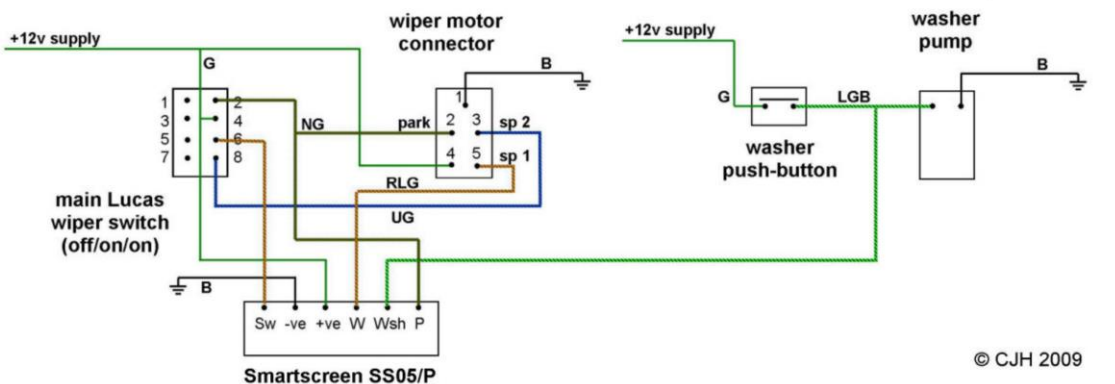

TROUBLESHOOTING SMARTSCREEN

- 1 Restore the wipers to original wiring.
- 2 Connect smartscreen unit +ve & -ve.
- 3 Wipers should work OK smartscreen does nothing.
- 4 If you have a smartscreen unit with wipe on wash then connect a wire from Wsh terminal to the washer switch so that when the washer switch is pressed either +ve or negative is applied to the Wsh terminal. If you have a SS05/P it is expecting a +ve if you have SS05/N it is expecting a -ve. You should hear the relay in the smartscreen click when you press the washer switch. The LED will not do anything.
- 5 Disconnect all wires from smartscreen. Now identify the wiper standard speed cable, normally red/light green, cut or add new cable so that end going to wiper is connected to W terminal, end going to wiper switch is going to Sw. The wipers should now work normally as the smartscreen is not powered and the wiper wire is linked inside the smartscreen.
- 6 Disconnect the W wire and connect +ve and -ve to smartscreen. Turn the wiper switch on and off, the Led should flash and the relay click.
- 7 If all OK repeat with the W terminal now connected. The wiper should wipe and the LED flash until you press the wiper switch a second time. The wiper will wipe again and then once by itself, the LED will be on all the time.
- 8 In order to get the unit to do more than 3 wipes the park wire needs to be spliced into the P terminal, this wire is normally brown/green.